

Rotary unit

ZD 30

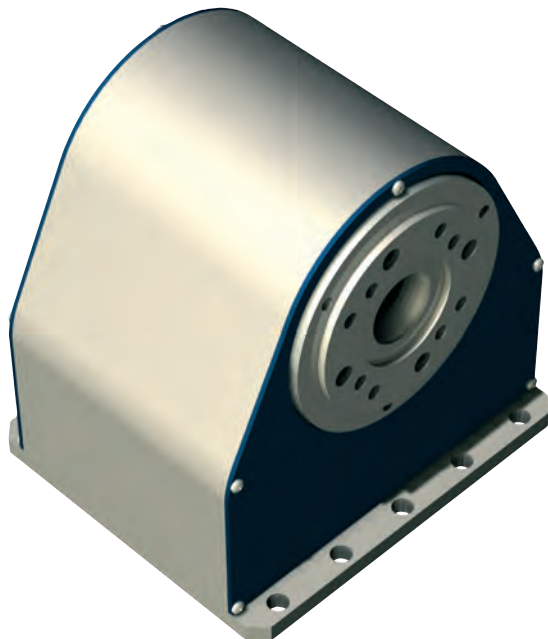

Features

- Low play toothed belt drive with Stepper motor
- Reduction 1 : 30
- Shaft with \varnothing 15 mm boring
- Housing flange with inner cone SK 20
- Weight: 2,9 kg

For pin assignment see page C122
For transport loads, see page C123

Options:

- CNC controller via Sub D

Ordering information

ZD 30 rotary unit
Art.-Nr.: **261100 0000**

Technical specification

		Stepper motor MS 045 HT *
Reduction ratio		1:30
Speed	[1/min]	0 - 40
Operating torque (0 - 1600 Hz)	[Nm]	12
Nominal holding torque (static load)	[Nm]	20
Min. step (positional accuracy)	[arcmin]	2.5

* Values for half-step operation

Accessories



Chuck assembly

3-jaw chuck \varnothing 65
Part no.: **269060 2065***



Chuck assembly

3-jaw chuck \varnothing 80
Part no.: **269060 3080***



Collet holder

Collet holder SK 20
for tools \varnothing 3 - 13 mm, with
installation ring
Part no.: **239172 0001**

Collets are on page E 29.



Tailstock unit RE-ZD30

200 mm Part no.: **269 100 1060** L 331
300 mm Part no.: **269 100 1070** L 431
400 mm Part no.: **269 100 1080** L 531
500 mm Part no.: **269 100 1090** L 631

* including flange

Rotary unit

ZD 30

Dimensioned drawing

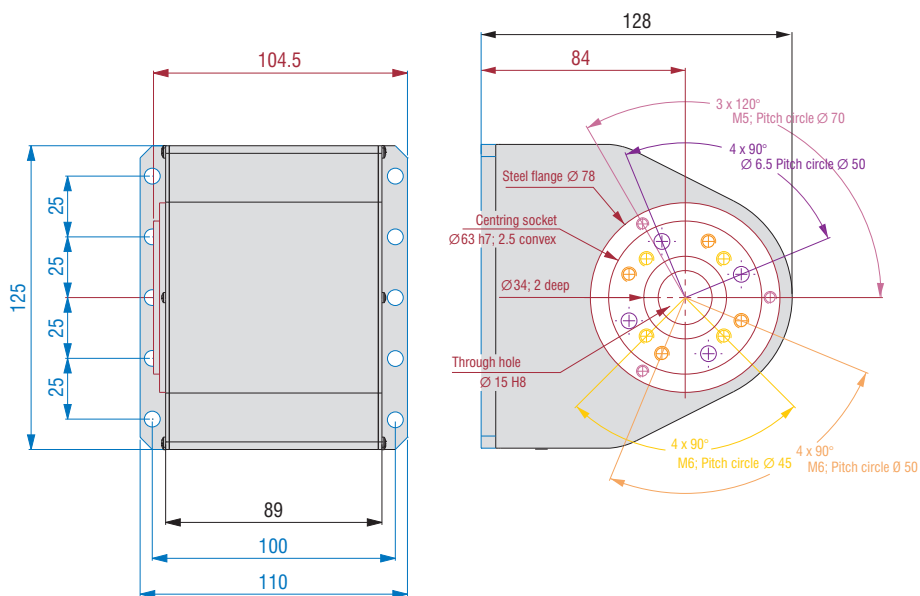

Tailstock unit RE-ZD30

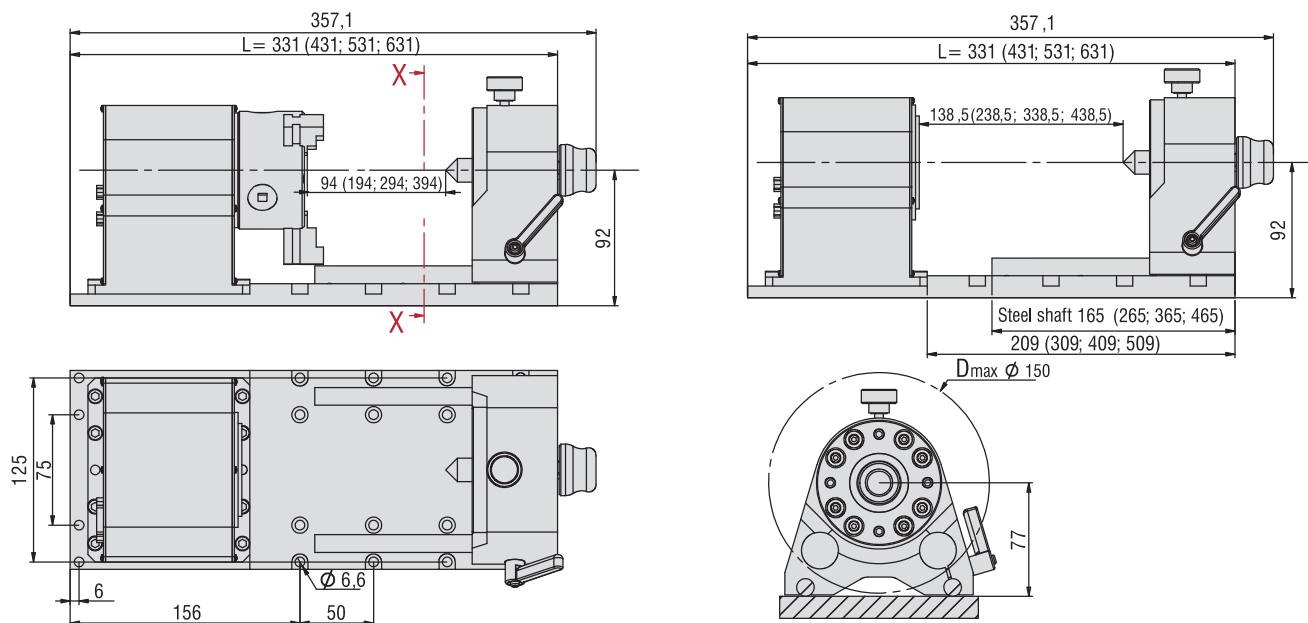

SECTIONAL DRAWING X-X

